

SMOKE-MASTER CONVECTION OVEN

Model 250 RFS Barbecue Pit

Stainless steel interior!

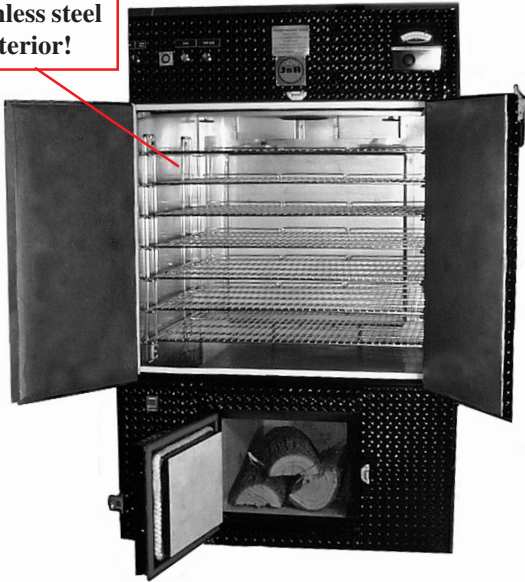

This large capacity pit (big brother to the Little Red Smokehouse) is wood fired but comes equipped with an electric oven heating element. This feature reduces wood consumption and allows you to craft the flavor of the meat to your exact preference. By using safe, clean electrical energy to assist the wood fire you will produce authentic barbecue without the “gassy taste” associated with gas/wood ovens. You can cook up to 600 pounds per load of briskets, pork butts, tri-tips, etc. Even cooking is assured with our unique high velocity convection air system, so no rotation of the meat will be required.

LOADED WITH FEATURES :

Easy to Use

Fire starting is easy with the built in stack fan providing draft and the combustion air fan providing oxygen. However, live coals last over 72 hours in the refractory lined firebox so most customers start a fire from scratch only once. After that, they just scoop out some ashes daily and add fresh wood. The coals and the pit do the rest to ignite the newly added wood. Loading and unloading are easy with the large doors and slide out racks. After loading, just set the thermostat and relax. The air control system will precisely maintain your selected temperature while you sleep.

Electric elements

Safe, clean electrical energy reduces wood consumption if you choose, thereby eliminating the hazard, foul taste, and odor of gas with its sulfurous components (mercaptans).

Economical

The Smoke-Master is incredibly efficient due to the unique temperature control design and heavy insulation. It cooks up to 600 pounds of meat yet requires less than 17 square feet of floor space!

Evacuation System

Just turn the evacuation switch and our damper and fan system goes into action to induce fresh air into the pit and exhaust the smoke out through the stack and not into your kitchen.

Cook and hold.

Set the cooking time and the initial cooking temperature. After the timer counts down, the pit temperature automatically resets to 145 degrees (holding temperature).

Easy to clean.

Removable racks and rack slides. The oven floor slopes to a large drain reservoir, which can be easily drained through a remote valve. Stainless steel interior.

Easy to vent.

Can be vented directly with six inch Class A stack or placed under a Type I exhaust hood.



J&R MANUFACTURING, INC.
P.O. BOX 850522
MESQUITE, TEXAS 75185-0522



PHONE: 972-285-4855
TOLL FREE: 800-527-4831
FACSIMILE: 972-288-9488

www.jrmanufacturing.com

Model 250 RFS Specifications

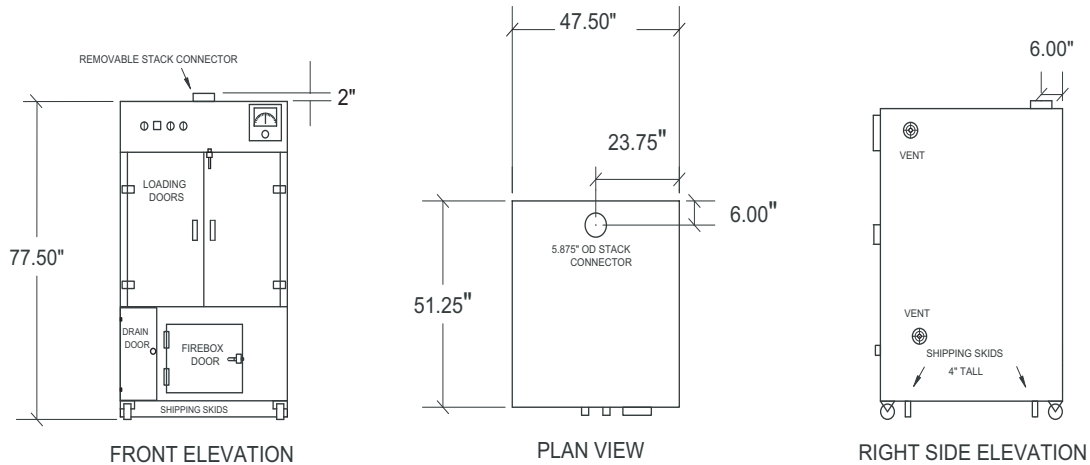

NOTES:

1. INSTALL ON A NON-COMBUSTIBLE FLOOR.
2. CLEARANCE FROM COMBUSTIBLES: 6" FROM THE REAR, 1" ON THE RIGHT AND LEFT, 12" AT THE TOP, 18" FROM THE STACK CONNECTOR, AND 48" FROM THE FRONT.
3. VENT THROUGH THE ROOF USING 6" DIAMETER "CLASS A" STACK AND FOLLOW MANUFACTURER'S INSTRUCTIONS REGARDING CLEARANCES. AS AN ALTERNATIVE TO DIRECT VENTING, THE UNITS CAN BE VENTED USING A TYPE ONE VENT HOOD INTERLOCKED ELECTRICALLY WITH THE UNIT SO THAT A HOOD FAN OUTAGE SHUTS DOWN THE UNIT. REFER TO NFPA 211 AND NFPA 96 FOR FURTHER DETAILS AND CHECK WITH LOCAL CODES FOR ANY FURTHER VENTING REQUIREMENTS.
4. THE ELECTRICAL REQUIREMENT IS 208/230 VOLT, SINGLE PHASE, 18.3 AMPS (4 WIRE: L1, L2, N, AND GRD.).
5. ACCESS TO THE REAR, TO THE RIGHT SIDE, AND TO THE TOP IS REQUIRED FOR SERVICE PURPOSES.
6. SEE OWNER'S MANUAL FOR ADDITIONAL INFORMATION.

CAPACITIES			
ROASTS	BACKRIBS	SPARERIBS*	CHICKEN
600 LBS	161 SLABS	70 SLABS	210 HALVES
7 Racks: 32"x39"		* 2.5 and down	

CONSTRUCTION... Extra heavy, all structural steel welded framing with 14 gauge stainless steel interior. Exterior front is 14 gauge epoxy coated steel treadplate. Exterior sides and back are 18 gauge epoxy coated steel. Color choices are red, black, or gray. The firebox and firebox flue are constructed from ten gauge steel lined with 2 inch thick, 2500 degree cast refractory. The oven, flues, and firebox are then wrapped with high temperature insulation. The controls such as relays, overloads, thermostats, and timers are located above the oven front and are accessed through a hinged cover above the oven doors. The oven racks are constructed of heavy nickel chrome plated wire.

Shipping weight: 2600 pounds